

Little GIANT[®]

10SH SERIES



Features

- Handles liquids and solid waste materials up to 1-1/4" diameter
- Cast iron pump housing and volute with protective epoxy coating for corrosion and rust resistance
- Oil-filled motor housing for lifetime lubrication and rapid heat dissipation
- Stainless steel fasteners
- Mechanical seals (stainless steel spring, nitrile parts, carbon and ceramic faces)
- Thermal overload protection
- Manual and Automatic models
- Automatic operation has 9" to 14" "On" level and 2" to 6" "Off" level range with piggyback mechanical float switch
- All models are UL/CSA listed

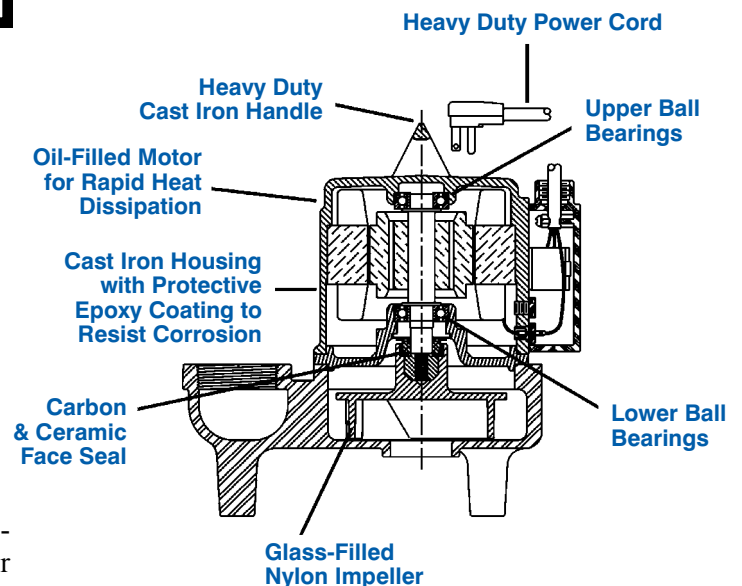

For increased pumping rates and higher head requirements, the Model 10SH Series Wastewater pumps offer greater head capacities than the 10S Series. Pumps feature a 2" discharge, with a lift of 28'. Cast iron housing and volute have a protective epoxy coating.

10SH SERIES

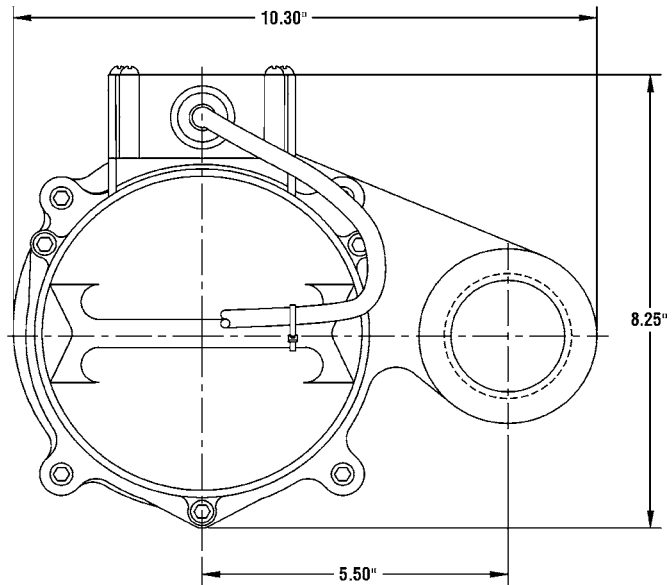
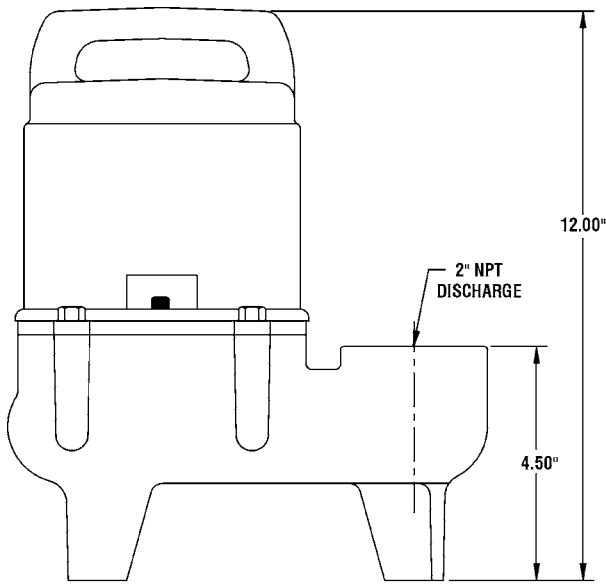

Specifications

MODEL NO.	ITEM NO.	LISTING	HP	VOLTS	SOLIDS SIZE (dia. in.)	RUNNING AMPS/WATTS	PERFORMANCE (GPM @ HEAD)				SHUTOFF (ft.)	P.S.I.	PWR. CRD. (ft.)	WEIGHT (lbs.)	DIMENSIONS (H x L x W in.)
							10'	15'	20'	25'					
10SH-CIM	511420	UL/CSA	1/2	115	1-1/4	11/900	100	80	55	20	28	12.1	15	44	12.00 x 10.3 x 8.25
10SH-CIM	511480	UL/CSA	1/2	208-240	1-1/4	5.5/900	100	80	55	20	28	12.1	15	41.5	12.00 x 10.3 x 8.25
10SH-CIA-RFS	511520	UL/CSA	1/2	115	1-1/4	11/900	100	80	55	20	28	12.1	15	41.5	12.00 x 10.3 x 8.25
10SH-CIA-RFS	511525	UL/CSA	1/2	115	1-1/4	11/900	100	80	55	20	28	12.1	25	46	12.00 x 10.3 x 8.25

10SH SERIES PUMP PERFORMANCE CURVE

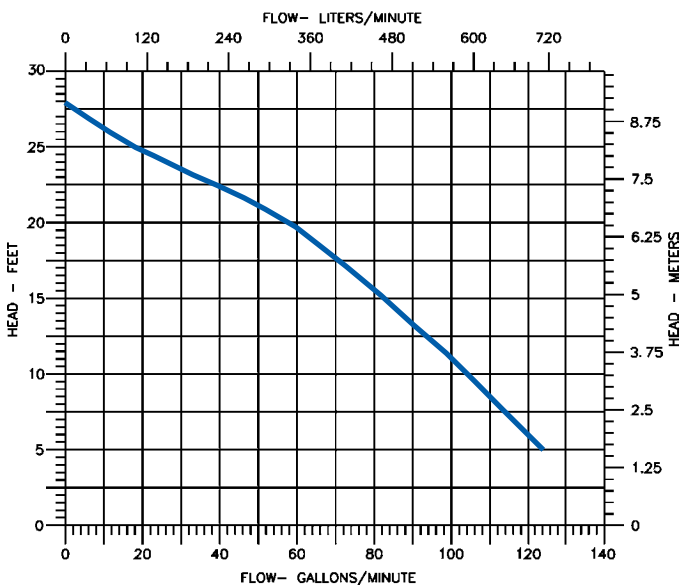

Construction

Motor Housing	Epoxy-coated cast iron
Impeller Material	Glass-filled nylon
Impeller Type	Vortex
Volute	Epoxy-coated cast iron
Power Cord	SJT/W/A
Mechanical Shaft Seal	Nitrile with carbon & ceramic faces
Fasteners	Stainless steel
Shaft	Steel
Bearings	Upper & lower ball bearings

Little GIANT®

16S SERIES



Features

- Handles liquids and solid waste materials up to 2" diameter.
- Cast iron pump housing with protective epoxy coating for corrosion resistance
- Oil-filled motor housing for lifetime lubrication and rapid heat dissipation
- Stainless steel screws, bolts and lifting ring
- Mechanical seals (stainless steel spring, nitrile parts, carbon and ceramic faces) for long life and reliability
- Secondary exclusion seal to help protect mechanical seal
- 1 HP ball bearing motor
- Thermal overload protection
- Permanent split capacitor design on single phase models
- Capacitor & power cord isolated from oil-filled motor housing for ease of field maintenance
- Dynamically balanced two-vane non-clogging impeller with pump-out vanes to protect seal

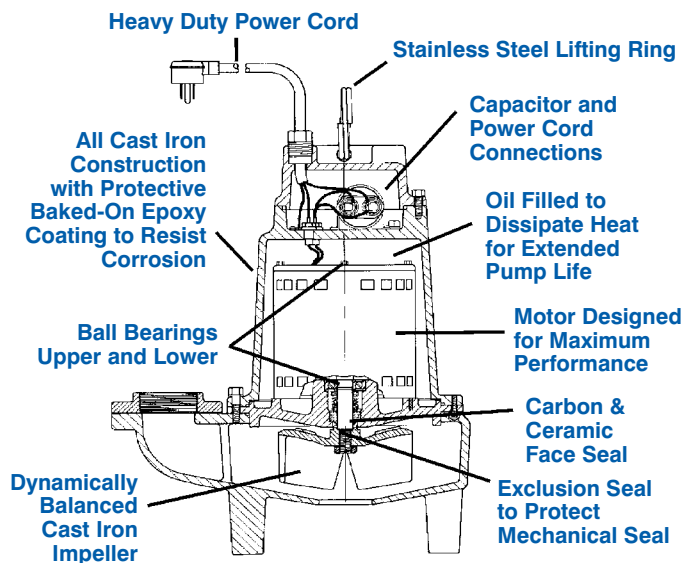

For residential, commercial, industrial and agricultural use. Pumps feature 3" FNPT discharge with a maximum head of 35', heavy duty cast iron construction and stainless steel hardware.

16S SERIES

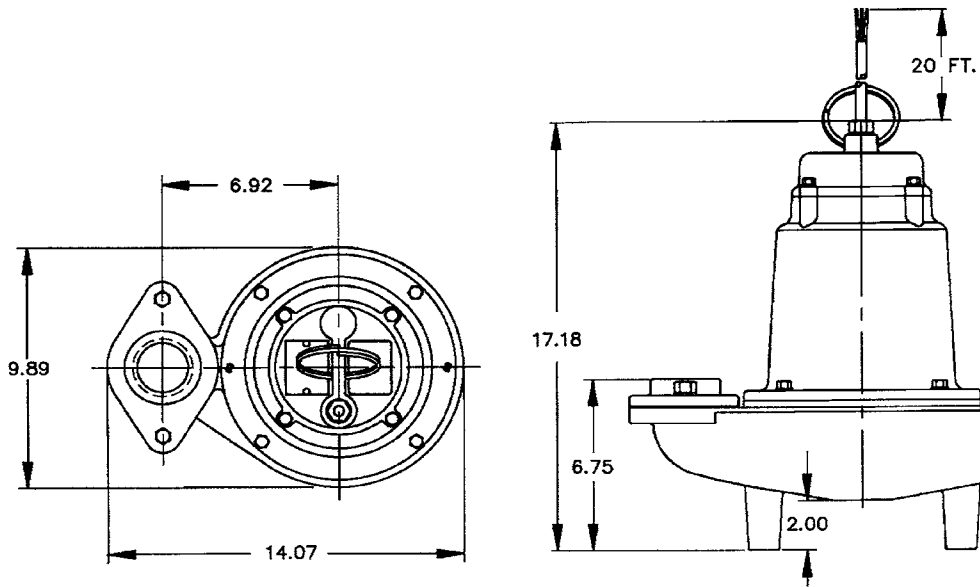

Specifications

Model No.	Item No.	Discharge	Solids Size (dia. in.)	Listing	HP	Volts	Ph.	Hz.	RPM	Amps/Watts	Shutoff		Cord Length (ft.)**	Weight (lbs.)
											Ft.	P.S.I.		
16S-CIM	514620	3" FNPT	2"	UL/CSA	1	230	1	60	1625	11.0/1900	35'	15.1	20'	88
16S-CIM	514630	3" FNPT	2"	UL/CSA	1	230	1	60	1725	11.0/1900	35'	15.1	40'	88
16S-CIM	514625	3" FNPT	2"	UL/CSA	1	200-208	1	60	1650	11.0/2000	35'	15.1	20'	88
16S-CIM	514720	3" FNPT	2"	UL/CSA	1	230	3*	60	1725	6.3/1550	35'	15.1	20'	88
16S-CIM	514730	3" FNPT	2"	UL/CSA	1	460/380	3*	60/50	1725	3.2/1400	35'	15.1	20'	88
16S-CIM	514740	3" FNPT	2"	CSA	1	575	3*	60	1725	2.5/1400	35'	15.1	20'	88
16S-CIM	514750	3" FNPT	2"	UL/CSA	1	200-208	3*	60	1725	6.8 Amps	35'	15.1	20'	88

Continuous Duty Rated — "Little Giant Wastewater pumps are rated continuous duty as long as they are run within the published ratings for these pumps."

*3 phase pumps require control panel to operate

**Without plug

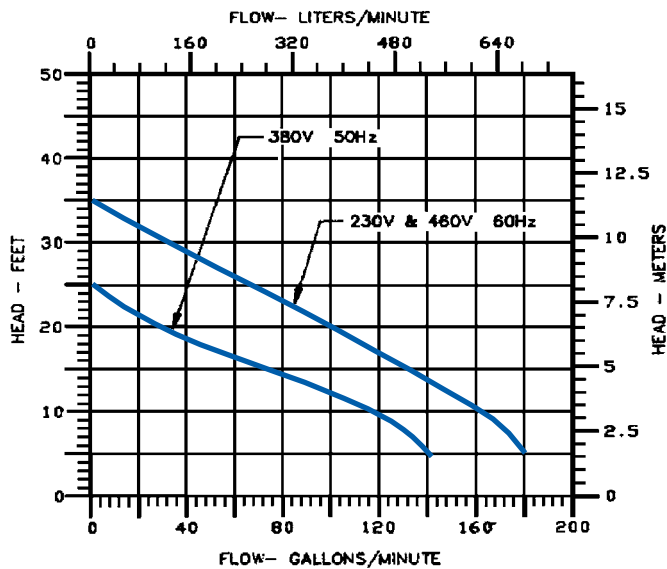

Construction

Motor Housing	Epoxy coated cast iron
Impeller Material	Epoxy coated cast iron
Impeller Type	Two vane, non-clog
Volute	Epoxy coated cast iron
Power Cord	16/3, STW
Mechanical Shaft Seal	Nitrile with carbon and ceramic faces
Fasteners	Stainless steel
Shaft	Stainless steel
Bearings	Upper and lower ball bearings